



**COUNCIL OF
THE EUROPEAN UNION**

Brussels, 19 June 2008 (20.06)

10963/08

COSDP 555

NOTE

from : European Union Military Staff

to : European Union Military Committee

No. prev. doc. : EUMC Mtg Doc 29/08

Subject : EU Concept for Logistic Support for EU-led Military Operations

Delegations will find attached the EU Concept for Logistic Support for EU-led Military Operations, which was agreed by the EUMC on 18 June 2008.

EU CONCEPT
FOR LOGISTIC SUPPORT FOR
EU-LED MILITARY OPERATIONS

TABLE OF CONTENTS

INTRODUCTION	6
B. AIM.....	6
C. SCOPE	6
D. DEFINITION AND PRINCIPLES	7
1. Definition	7
2. Principles.....	7
E. General characteristics and factors affecting logistic support	10
1. General Characteristics	10
2. Factors Affecting Logistic Support.....	10
F. EU General Logistic Support Guidelines.....	13
1. Resources	13
2. Sustainability.....	14
3. Delineation and Transfer of Authority.....	15
4. Redistribution.....	15
5. Legal Aspects.....	16
G. LOGISTIC FUNCTIONS	17
1. General	17
2. Supply	17
3. Maintenance	18
4. Services/ Life Support.....	18
5. Movement and Transportation.....	18
6. Infrastructure Engineering Support to Logistics.....	20
7. Health and Medical Support	20
H. Logistic Related Areas	21
1. Reception, Staging, Onward Movement & Integration	21
2. Financing and Budgeting	21
I. MODES of Logistic Support.....	22
1. Introduction.....	22
2. National Logistic Support	22
3. Multinational Logistic Support	22
4. Host Nation Support.....	25
5. Contracting and Third Party Logistic Support.....	26
6. Recourse to NATO Common Assets and Capabilities	27
J. Logistic Information and Management.....	28
K. LOGISTIC PLANNING	28
L. COMMAND AND CONTROL STRUCTURE. TASKS AND RESPONSIBILITIES	30
1. General	30
2. Political and Strategic Level	30
3. Military Strategic Level	32
4. Military Operational Level.....	33
5. Military Tactical Level.....	35
6. Structure Outline	36
Annex A	37
LOGISTIC PLANNING CONFERENCES.....	37

References

- A. European Security Strategy (Council Doc 15895/03 dated 08/12/03);
- B. Treaty on European Union;
- C. Headline Goal 2010 (Council Doc 6309/6/04 dated 04/05/04);
- D. EU Military Rapid Response Concept (Council Doc 5641/1/03, dated 24/01/2003);
- E. EU Battle Group Concept (Council Doc 13618/06 dated 05/10/2006);
- F. An Initial Long-Term Vision for European Defence Capability and Capacity needs.(EDA. LTV- 03 OCT 2006 - SB MoDs Levi);
- G. EU Concept for Force Generation (Council Doc 10690/08 dated 16/06/08);
- H. Mainstreaming Human Rights and Gender into European Security and Defence Policy - Compilation of relevant documents (Council Doc 11359/07, dated 29 October 2007);
- I. Agreement between the Member States of the European Union concerning the status of military and civilian staff seconded to the institutions of the European Union, of the headquarters and forces which may be made available to the European Union in the context of the preparation and execution of the tasks referred to in Article 17(2) of the Treaty on European Union, including exercises, and of the military and civilian staff of the Member States put at the disposal of the European Union to act in this context (EU SOFA) (Council doc 13028/03, dated 04/11/03);
- J. Draft Model Agreement on the status of the European Union-led Forces between the European Union and a Host State (Council Doc 11894/07, dated 20/07/07, 11894/07 COR 1, dated 05/09/07);
- K. EU Concept for Strategic Movement and Transportation for EU-Led Military Operations (Council Doc 10967/08 dated 19 June 2008);
- L. Military Engineering Concept for EU-led Military Crisis Management Operations (Council doc 11853/07, dated 13/07/2007);
- M. Health and Medical Support Concept for Military EU-led military CMOs, Revision 1 (Council Doc 10901/07 COR 1, dated 05/07/2007);
- N. EU Concept for Reception, Staging, Onward Movement & Integration for EU-led Crisis Management Operations (Council Doc 10971/08 dated 19 June 2008);
- O. Council Decision 2007/384/CFSP of 14 May 2007 establishing a mechanism to administer the financing of the common costs of EU operations having military or defence implications (Athena) (OJ L 41, 13.02.2007, p.119);
- P. Athena Special Committee decision - Financial rules applicable to expenditure financed through ATHENA- (Athena Special Committee doc. SN 1913/06 dated 17/03/06);

- Q. EU Framework Nation Concept (Council Doc 11278/02 dated 25/07/02);
- R. Host Nation Support Concept for EU-led Military Crisis Management Operations, Revision 1 (Council Doc 0603/06 dated 15/06/2006);
- S. NATO SG letter to SG/HR Ref SG (2003) 0350 dated 17/03/2003; SG/HR letter to NATO SG Ref SGS3/2528 dated 17/03/2003MC 319/2. (BERLIN + Arrangements);
- T. List of pre-identified NATO capabilities and common assets that would be presumptively available for use in EU-led military CMOs (SG (2003)0192, dated 18 February 2003, NATO Restricted releasable to the EU);
- U. EU Concept for Military Planning at the Political and Strategic Level (Council Doc 10687/08 dated 16/06/08);
- V. EU Concept for Military Command and Control (Council Doc 10688/08 dated 16/06/08);
- W. Draft Agreement between the EU and some Third States establishing a framework for the participation of some Third States in the EU CMO (Framework Participation Agreement) (Council Doc 6284/04 dated 17/02/2004);
- X. Draft Model of participation agreement between Third States and the EU in ESDP military operations (Council Doc 12047/04 dated 03/09/2004);
- Y. Presidency Conclusions of Nice European Council meeting, dated 07/08/09 DEC 2000 (Council Doc SN 400/1/00, Rev 1);
- Z. Suggestion for procedures for coherent, comprehensive EU Crisis Management (Council Doc. 11127/03, dated 03/06/05).

A. INTRODUCTION

1. The European Security Strategy (ESS) (Ref. A), adopted in 2003 by the European Council, acknowledges that the European Union (EU) is a global player ready to share in the responsibility for global security. The strategy calls upon the EU to become more active, more capable and more coherent, and to work closely with partners. Within the framework of ESDP, the ESS elaborates additional tasks to the set of missions and tasks explicitly identified in Article 17.2 TEU (Ref B), to also include joint disarmament operations, support for third countries in combating terrorism and security sector reform.

2. This concept reflects the political aspirations within the military dimension of ESDP as well as the practical military experience gained during EU-led military operations. It should be updated in the light of experience gained from operations but also regarding technological developments in all areas and dimensions, in order to support future operations.

B. AIM

3. The aim of this document is to establish the overarching concept for logistic support for the entire spectrum of EU-led military operations.

C. SCOPE

4. This document details EU logistic principles and guidelines, primarily at the Political and Strategic level but also at the military Strategic and Operational levels, to foster common understanding and co-operative logistic planning for any EU OpCdr and FCdr and the respective levels in the MS. It provides sufficient flexibility for close co-operation with NATO, UN, OSCE, other relevant International Organisations (IOs) and for non-EU Troops Contributing Nations (non-EU TCNs) participating in EU-led military operations. It takes into account new challenges deriving from the HLG 2010 (Ref C), the specific challenges related to a Rapid Reaction Capability (RRC) (Ref. D), the EU Battlegroups (EU BGs) (Ref. E) and the logistic lessons identified during recent EU-led military operations. This Concept is harmonised with logistic documents from NATO to the maximum extent possible.

D. DEFINITION AND PRINCIPLES

1. Definition

5. Logistics is the science of planning and carrying out the movement and maintenance of forces. In its most comprehensive sense, it is the aspects of military operations which deal with:

- a. Design and development, acquisition, storage, movement, distribution, maintenance, modification, evacuation and disposition of materiel;
- b. Transport of personnel;
- c. Acquisition or construction, maintenance, operation, and disposition of facilities;
- d. Acquisition or furnishing of services and
- e. Health and Medical (H&M) service support¹.

6. The term logistics, if not otherwise stated, comprises all the logistics functions and logistic related areas, although materiel management and procurement logistics is beyond the scope of this document.

2. Principles

7. In order to execute their responsibilities for logistics efficiently, EU military Commanders (Cdrs) and their staffs at all levels need to follow a number of logistic principles. These principles are listed below:

a. Primacy of Operational Requirements

8. Logistic support must be focused on meeting the operational requirements necessary to ensure the success of the operation in all its phases.

b. Collective Responsibility

9. The responsibility for the provision of resources and for planning the support of national forces remains ultimately with the TCNs. Nevertheless, MS and non-EU TCNs have a collective responsibility for logistic support of EU-led military operations. This collective responsibility principle encourages to closely co-operate from the beginning of the planning process and to share the provision and use of logistic capabilities and resources to support the force effectively and, whenever possible, efficiently. Interoperability, co-operation and standardisation of procedures, provides the basis for multinational and efficient logistic support that will contribute to operational success.

¹ DE does not recognise H&M support as a logistic function but as a logistic related area.

c. Authority

10. There is an essential interdependence between responsibility and authority. The responsibility assigned to any EU military Cdr must be matched with the delegation of authority by TCNs to allow the adequate discharge of responsibilities. The EU military Cdrs at the appropriate level must be given sufficient authority over the logistic resources necessary to enable him to receive, employ and redistribute the logistic assets required to sustain the forces assigned to him by TCNs, in accordance with pre-agreed terms and conditions, in the most effective manner.

d. Co-operation

11. Multinational co-operation among EU military Cdrs, MS, non-EU TCNs and Third States as well as other organisations is essential. Co-operation across all functions of logistic support will contribute to efficient/best use of limited resources.

e. Co-ordination

12.. Co-ordination of logistic support between relevant EU actors and TCNs is essential and must be carried out at all appropriate levels, and also with other states, IOs and other organisations as required. Generic and pre-arranged agreements and/or arrangements are the tools to facilitate logistic co-ordination and this may require the appointment of national representatives or liaison officers in multinational logistic command structures at the military strategic, operational and, if appropriate, tactical levels to ensure that TCNs are aware of and react appropriately to both national and EU operational priorities, and that such priorities are harmonised. Overall responsibility for co-ordination lies with the EU military Cdrs and should be conducted as a matter of routine.

f. Assured Provision and Sufficiency

13.. TCNs must ensure, either individually or through co-operative arrangements, the provision of adequate logistic resources of the appropriate quantity and quality to support their forces while executing EU-led military operations. Logistic resources must be both sufficient to achieve designated levels of readiness, sustainability and mobility and to provide the required military capability necessary for the conduct of EU-led military operations.

g. Flexibility

14. Logistic support must be proactive, adaptable and responsive to accomplish the mission. Planning that considers potential changes in circumstances enhances flexibility.

h. Simplicity

15. Simple plans and orders and uncomplicated mission-oriented logistic organisations minimise confusion. They help to ensure that the support provided meets the operational requirements. Furthermore, simple reporting mechanisms ensure the accurate and efficient dissemination of information.

i. Timeliness

16. Developing and implementing an effective logistic framework requires considerable planning and co-ordination during all phases of the operation between relevant EU actors and TCNs. Since the most critical phase of logistic execution is deployment and initial operational set-up, it is essential that national and multinational logistic command and control elements and enabling forces are established before main deployment begins.

j. Effectiveness/Efficiency

17. Logistic resources have to be used effectively and as efficiently as possible, mindful of the primacy of operational requirements. Mutual support structures and mechanisms, such as multinational logistic organisations, Host Nation Support (HNS) and Contracting/Third Party Logistic Support (TPLS) should be utilised whenever practical to reduce costs, eliminate duplication of logistic effort and improve the overall quality of support. The goal is to achieve these advantages and simultaneously to optimise the 'logistic footprint'.

k. Visibility and Transparency

18. Visibility and transparency of the availability of logistic resources are essential for effective logistic support. EU military Cdrs require timely and accurate information from TCNs concerning logistic assets and capabilities to achieve synchronised, integrated and effective support to the EU-led Forces.

l. Synergy

19. Synergy is the expanded benefit achieved by applying logistic principles simultaneously. Synergy results when TCNs contribute to a common goal with the net benefit being greater than the sum of their separate contributions. To be truly efficient, any multinational organisation must build upon the strengths of the component parts. Multinational logistic support in the overall concept should be oriented to the particular logistic strengths of the TCNs. This serves to provide more efficient support to the overall force and thereby creates a more robust military logistic concept.

m. Multinationality

20. Multinational logistics is a means by which, depending on operational requirements and the specific situation, the TCNs can enhance their efficiency and effectiveness. For EU-led military operations the use of multinational logistic structures and appropriate multinational solutions will be sought at the earliest opportunity to solve the military logistic support and to optimise the logistics footprint commensurate with the operational need. The most efficient EU response in EU-led military operations will be improved if multinational logistic concepts and capabilities are developed, negotiated and agreed early during the operational planning process and implemented in advance of deployment for operations.

E. GENERAL CHARACTERISTICS AND FACTORS AFFECTING LOGISTIC SUPPORT

1. General Characteristics

21. The operational environment for EU-led military operations is likely to be characterised by great distances and consequently long Lines of Communication(s) (LOCs), difficult terrain, hostile climate, scarcity of basic facilities and limited HNS.

22. EU-led military operations are likely to be ad hoc in nature, rapid, expeditionary (Ref. F) combined and joint. In addition, more than one EU-led military operation may occur at the same time, anywhere in the world, possibly involving more than one Host Nation (HN) and lasting for protracted periods.

23. All these conditions determine challenging scenarios that may have a considerable impact on the size of the logistic effort necessary to sustain the force and to enable it to operate effectively. In this environment it is necessary to assume austere conditions, mainly in the initial phase, especially in Life Support (LS).

2. Factors Affecting Logistic Support

a. Civil-Military Activities

24. EU-led military operations are often conducted alongside civilian activities that could commence well ahead of the decision to launch an operation and may extend into the immediate post crisis period. The EU must therefore have a logistic support system able to cope with the requirements arising from such a situation. EU-led military operations could also be conducted in combination with a civilian EU mission.

25. Beyond the support of the deployed forces, EU-led military operations may require programmes for the benefit of local or displaced persons. Such commitment may include, among others, provision of food and drinking water, medical support and construction projects. In order to deliver such support, sufficient transportation resources will be essential. Moreover, the nature of EU-led military operations could require logistic support to civilian activities of IOs and Non-Governmental Organisations (NGOs). In this case, specific arrangements, including funding, have to be established.

26. The possibility that an EU-led military operation takes place in a country/region where the UN is present is high. Moreover any EU-led military operation could be undertaken in support to a UN operation. Therefore, EU logistic support needs to be closely co-ordinated with UN and UN agencies both on the ground and during the planning phase. Both organisations can co-ordinate the provision of logistic support during the operation but, in addition, the EU-led force could also profit from the presence of the UN in the Joint Operations Area (JOA) at the beginning of the operation when the EU logistic chain of support has still to be established (or vice versa).

27. To avoid competition and support difficulties in severely limited markets, it is important to co-ordinate the use of HNS or the local market with the other IOs and NGOs present in the JOA, as early as possible.

b. Availability of Resources

28. The level of participation/contribution of MS, non-EU TCNs and Third States to a specific operation may vary considerably, which could affect the collective availability of resources for an EU-led military operation.

29. EU-led military operations may occur where HNS is very limited or non existent.

30. Military logistic support requirements must be matched against available resources. Logistic planners have to take into account logistic support limitations. Plans have to be checked and, if necessary, be revised on a continuous basis. They should consider all possible alternatives that produce efficient solutions.

31. In order to cater for the initial expenses derived from early activities leading to the launching of an EU-led military operation of any size, the finances required from MS for certain elements of common costs could be required prior to the adoption of the decision to launch the operation.

c. Readiness

32. Lead time in the Force Generation (FG) process (Ref G) must take into account that there are neither permanent military command structures nor permanently assigned forces under the authority of the EU.

33. The availability and readiness levels of logistic units and resources must match the readiness state of forces allocated to EU-led military operations and in particular the rapid response formations, like the standby EU BGs, the Air and the Maritime RR elements. Therefore, logistic support within a rapid response scenario must be in line with the EU Military RR Concept (Ref D).

d. Legal Aspects

34. EU-led military operations are to be conducted in accordance with the legal framework of these operations, which is normally spelled out in each operation's OPLAN.

e. Human Rights and Gender

35. The mainstreaming of human rights and gender (Ref. H) within EU-led military operations deserves particular interest and may have some impact on logistic requirements. This refers to women deployed within EU-led military operations, to women and children, who are or have been members of armed forces of parties of a conflict, as well as to women and children who are members of the civil society within the JOA. It may result from specific needs of women and children as well as from activities to promote gender equality and the role of women in post conflict situations.

f. Interoperability

36. Interoperability is considered as a broad framework that includes military, civilian and civil-military aspects, as well as technical, procedural and cultural levels. A coherent and co-ordinated development of compatible equipment, procedures, command arrangements, defence planning and spirit is a primary objective. The capability to operate together in multinational structures and forces may be hampered by different levels of logistic interoperability among the MS and non-EU TCNs.

g. Standardisation

37. Standardisation of materiel, resources, services and procedures has a direct impact on interoperability, sustainability and effectiveness and should be encouraged as far as possible. Whenever applicable NATO standards are to be used.

h. Protection of the Logistic Chain

38. When operating in a non-benign environment, the robust protection of the entire logistic chain becomes a significant consideration, in order to assure the sustainability of the whole force. Such protection will take place in accordance with the legal framework. The need for additional Force Protection (FP) units has to be recognised from the start of the operational planning phase and addressed properly in the Statement of Requirements (SOR) (Ref G). Furthermore, EU-led Forces may have to provide FP, if necessary, to employed/deployed civil personnel and contractors' personnel directly involved in logistic support of EU-led Forces.

i. Environmental Protection

39. Both national and international legislation and agreements on Environmental Protection (EP) increasingly affect EU-led military operations. The implications of EP for the execution of logistic functions in support of EU-led military operations must be taken into account.

F. EU GENERAL LOGISTIC SUPPORT GUIDELINES

1. Resources

40. The logistic support appropriate for an EU-led military operation has to be identified early in the operational planning process, considering multinational approaches to the maximum extent possible. Supplies and services provided by Nations, where appropriate, may be augmented by HNS, local procurement, contracting/TPLS and/or by multinational co-ordinated provision as agreed among TCNs.

41. TCNs will retain control over their own logistic resources, until such resources are released to the EU military Cdrs according to the Transfer of Authority (TOA) arrangements. Once contributed, resources should not be withdrawn without appropriate notice.

42. EU military Cdrs require clearly defined authority to establish a support organisation to meet the operational requirement. TCNs must provide the EU military Cdrs at the appropriate level, with the authority to support the forces by using logistic resources in JOA. The EU military Cdrs co-ordinate support among TCNs and with the HN(s) and retain the responsibility to co-ordinate the overall logistic effort even when participating nations rely solely on national logistics.

43. On EU-led military operations, it is essential that the OpCdr has the means and the authority to co-ordinate all logistic resources that directly impact on the support of the operation. This also applies to the strategic deployment of forces, the sustainment effort and redeployment of both common and specific resources. In any case, close co-operation with TCNs, NATO (in the case of recourse to NATO common assets and capabilities), other IOs, NGOs and HN(s) will be required.

44. The acquisition of scarce local resources at theatre level should be conducted in accordance with operational priorities, as defined by the OpCdr, to avoid competition for scarce resources among TCNs and to avoid counterproductive influence on the local market, which could have a negative impact on the local population and as consequence adverse effects on the mission.

45. The EU military Cdrs will be kept informed of the logistic levels of sustainability and availability by TCNs. The deployment of stocks in-theatre may begin prior to or concurrently with the flow of units and personnel; this will be entirely dependent on the nature of the operation. Early establishment of logistic infrastructures and supporting Command and Control (C2) organisations will be essential in order to manage properly the Reception, Staging, Onward Movement and Integration (RSOM&I) process for personnel and materiel. Appropriate planning and information systems should be exploited to facilitate this process. The availability of pre-deployed logistic assets by TCNs in theatre will have a decisive impact on logistic capabilities for rapid response.

2. Sustainability

46. TCNs are responsible for meeting sustainability requirements established in the Operation Plan (OPLAN). The provision of logistic assets must meet the anticipated intensity and duration of the operation. The question of rotation of units and their associated support must be considered early in the planning process. Operating in unusual and adverse conditions can cause increased wear and tear, and may require the provision of additional resources. Furthermore, a requirement to support the local population, IOs or NGOs may increase the sustainment burden.

47. Sustainability considerations will affect the composition of the force packages. A sustainability statement for the specific operation developed by the OpCdr and agreed at the earliest stage by TCNs, will provide common criteria for the national contingents and ensure mission effectiveness. Such a statement is required to set the logistic order of battle, supplies stockpiles, maintenance and medical policies.

3. Delineation and Transfer of Authority

48. TCNs will retain Full Command over their logistic forces. TCNs will, in the TOA arrangements, specify the command relationships of logistic units within the national force contribution to the OpCdr. In a multinational logistic organisation, EU military Cdrs must be given sufficient control over logistic resources dedicated to the multinational role. This logistic control could be extended over the NSEs to allow the EU military Cdrs to co-ordinate, prioritise and deconflict logistic issues. But nationally-owned resources normally remain under national command and control unless there is a specific disposition to the contrary in the TOA message (LOGCON²). The EU will draw upon existing NATO doctrine, whenever possible, to ensure a comprehensive and acceptable approach to multinational formations and units thus ensuring harmonised logistic support across all TCNs.

4. Redistribution

49. TCNs have first call on the logistic resources integral to their forces. However, in exceptional circumstances, EU military Cdrs may direct the redistribution of national logistic resources to overcome unanticipated deficiencies. Redistribution is not intended to redress national stockpile shortages.

50. Redistribution is a logistic measure, offering the EU military Cdrs the possibility to transfer logistic resources within forces under their command, for a specific objective, within a limited time, in response to a critical operational need. This measure provides greater flexibility in logistic support, but it requires co-operation, co-ordination and the agreement of TCNs prior the commencement of the operation.

51. EU military Cdrs have, in their area of responsibility, the authority to redistribute the logistic assets in accordance with pre-agreed terms and conditions. Redistribution authority is limited to the EU military Cdrs, who have delegations in line with the TOA arrangements. The EU military Cdrs might consider logistic resources, assets and personnel for redistribution if essential for operational mission accomplishment.

² That authority granted to an EU Commander over assigned logistics units and organisations in the JOA, including National Support Elements (NSE), that empowers him to synchronise, prioritise, and integrate their logistics functions and activities to accomplish the joint theatre mission. It does not confer authority over the nationally-owned resources held by an NSE, except as agreed in the Transfer of Authority.

52. Logistic resources held by units under EU Cdr's OPCON/LOGCON are subject to redistribution within the limitations stated in the TOA message. Resources within the NSE, or any other logistic resources declared unavailable by TCNs are not subject to redistribution. However, this does not preclude EU military Cdrs from requesting assistance from a national contingent or NSE Cdrs when deemed necessary.

53. If time allows prior to effecting redistribution or as soon as practical afterwards, the EU military Cdrs will advise the affected national authorities and higher EU military Cdr of the redistribution action(s). Upon determination that redistribution is required, the EU military Cdrs will direct Cdrs of NSE(s) to effect the transfer of the logistic resources. As soon as the operational situation permits, the logistic resources transferred under this authority will be reimbursed or replaced. The mechanism for this must be laid down in appropriate arrangements.

5. Legal Aspects.

54. Military logistic support planning must incorporate the applicable legal framework during all phases of EU-led military operations.

55. Status of Forces Agreement (SOFA), transit and HNS arrangements are particularly important for the logistic support of the force.

56. The EU SOFA (Ref. I) applies within the territory of the EU MS and can be used within the framework of EU-led military operations when into force. It will enter into force on the first day of the second month following the notification by the last signatory MS (some MS became party through the Treaty of Accession) on the completion of its constitutional procedures.

57. Ad-hoc agreed SOFA(s) with Third States will be required to ensure an adequate legal status for forces outside the territory of the EU MS. Such negotiations will be based on the draft Model SOFA (Ref. J). Within the limits of their applicability SOFA(s) provide a legal basis for subordinate arrangements (e.g. Memorandum of Understanding (MOU), Technical Arrangement (TA), HNS Arrangement, Third Party Logistic Support (TPLS) arrangements, etc.).

58. The observance of the legal framework is crucial for all logistic support including its planning (e.g. financial issues and plans, contracting, claims).

G. LOGISTIC FUNCTIONS

1. General

59. Various logistic functions come together to form the totality of logistic support. Efficient logistic support depends on the co-ordination and synchronisation of procedures.

60. Based on the size and characteristics of the operation, the capabilities available, and other operational considerations, the OpCdr should consider different options for the execution of the logistic functions (e.g. from the land, from the sea, etc).

2. Supply

61. This logistic function encompasses timely provision of all classes of supply necessary to ensure the sustainability of forces. It covers the determination of stock levels, provisioning, timely distribution and replenishment. The classes of supply for EU-led military operations are:

- Class I: Items of subsistence;
- Class II: Supplies for which allowances are established by tables of organisation and equipment, e.g. clothing, weapons, vehicles, etc;
- Class III: Petroleum, oil and lubricants (POL) for all purposes, e.g. gasoline, fuel, oil, grease, coal and coke;
- Class IV: Supplies for which initial allowances are not prescribed by approved issue tables. Normally includes fortification and construction materials, as well as additional quantities of items identical to those authorised for initial issue (Class II) such as additional vehicles;
- Class V: Ammunition, explosive and chemical agents of all types;
- Other Supply Items: Pharmaceutical and medical material.

62. The provision of supplies to assure an adequate sustainment of EU-led Forces is a national responsibility. However, multinational solutions to provide EU-led Forces with a wide number of items of supply, such as: food, water, POL, standardised ammunition, pharmaceutical and medical material and, in general, standardised or common logistic assets could be easily adopted.

63. There are different ways to manage the supply flow to the JOA. Although this activity is a national responsibility, it is necessary to integrate and synchronise the whole supply flows into it, with the general flow of units and resources.

3. Maintenance

64. Maintenance includes all actions taken to retain equipment or material in/or to restore it to a specified condition, including inspection, testing, servicing, classification as to serviceability, repair, rebuilding and reclamation. In general maintenance embraces all supply and repair action taken to keep a force in condition to carry out its mission.

65. All equipment used by EU-led Forces must be maintained fit for purpose. Commonality and interoperability of equipment will play a key role in this domain and can significantly improve operational capability at both national and multinational levels. In this respect, bilateral or multilateral agreements should be sought, whenever equipment is used by more than one TCN. The collocation of multinational maintenance capabilities in theatre, e.g. battle damage repair capabilities, could also be considered to facilitate technical assistance, enhance co-operation and optimise the logistic footprint.

66. The use of HN(s) and/or civilian capabilities and resources to augment limited military maintenance capabilities in order to meet the operational requirements should be considered when and where security permits.

4. Services/ Life Support

67. LS is defined as encompassing all functions required to maintain adequate living conditions for deployed personnel in the JOA. As a minimum, it is focused at ensuring their survival. LS standards may rise if the situation permits and over the duration of the operation. LS covers a wide variety of activities in support of EU-led military operations, such as: laundry, canteen, bathing services, catering, accommodation, courier, etc.

68. Notwithstanding that each nation is responsible for ensuring the provision of LS to their own forces, because of the multinationality of EU-led military operations it is necessary to define standards for LS, mainly for contracting purposes. Nevertheless, it should be noted that EU-led military operations may take place in operational environments where it may be necessary to assume, at least in the initial phase, limited LS.

5. Movement and Transportation

69. Movement & Transportation (M&T) includes the whole spectrum of infrastructure, organisation, facilities and equipment necessary for the deployment, sustainment and redeployment of EU-led Forces during the execution of an operation.

70. TCNs are ultimately responsible for obtaining transportation resources and for planning and co-ordinating the movement to deploy, sustain and redeploy their forces and other forces if applicable. The responsibility for the deployment of multinational Headquarter(s) (HQs) and units with a high degree of multinationality may be assigned to a Framework Nation (FN) or a Logistic Lead Nation (LLN)³.

71. For EU-led military operations involving long distances and/or prolonged periods of operations, sufficient strategic and intra-theatre lift assets must be available. Without such assets, the development and subsequent execution of an OPLAN might be severely restricted. Where TCNs strategic lift assets are scarce it may be necessary to activate pre-planned arrangements or contracts to provide an initial air transport capability for EU-led military operations. These arrangements should take account of the need for co-operation, co-ordination and economy.

72. Onward movement within the theatre along the chain from Port(s) of Disembarkation (POD) through staging and/or marshalling areas into final destination must have the infrastructure, material handling equipment and means of transport necessary to deliver the forces and their associated logistic support. Intra-theatre M&T arrangements should also allow for the timely reverse flow of material and personnel.

73. Within the framework of the mission, the OpCdr is responsible for co-ordinating, prioritising and de-conflicting national deployments, transportation for sustainment (re-supply), and redeployment of national force contingents at the operational level. This work should be carried out by the EU Movement Co-ordination Centre (EUMCC)⁴, in conjunction with the participating TCNs concerned, using appropriate co-ordination bodies at all levels. These may include (but not limited to) the Movement Co-ordination Centre Europe (MCCE) and the Athens Multinational Sealift Co-ordination Centre (AMSCC).

74. M&T principles and policies are further elaborated in the EU Concept for Strategic Movement and Transportation for EU-led Military Operations (Ref. K).

³ LLN is defined in paragraph 91 (I.3.b).

⁴ See Ref. K for further information.

6. Infrastructure Engineering Support to Logistics

75. Infrastructure Engineering Support to Logistics (IESL) is an essential enabler for logisticians to accomplish their mission and support the overall operation. It covers "the construction, restoration, acquisition, repair, maintenance and disposal of those infrastructure facilities required to mount, deploy, accommodate, sustain and redeploy military forces, including the construction, restoration and maintenance of land LOCs and facilitation of Environmental Protection (EP)" (Ref. L).

76. IESL may be provided by the deployed EU-led force, HN(s), units of the NSE(s) or contractors. Logistics experts at all levels must work with engineers to ensure that engineering force and capabilities requirements are adequately addressed, and that adequate IESL assets and capabilities have been taken into account. The priorities established for IESL within theatre will influence efforts in HNS negotiations, CIMIC, public information operations, budgeting and contracting that will support the IESL effort.

77. Given the complexity of the IESL responsibilities defined in the Military Engineering Concept for EU-led military CMOs (Ref. L), funding of IESL projects in the context of EU-led military operations is a key issue that needs to be addressed very early in the logistic planning process in order to solve identified infrastructure shortfalls.

7. Health and Medical Support

78. TCNs retain the ultimate responsibility for the provision of H&M Support to their forces allocated to an EU-led military operation. This may be arranged in a number of ways, including agreements with other TCNs and organisations in order to prevent unnecessary redundancies and to economise critical medical resources. The OpCdr and/or the FCdr, supported by the Medical Director, may be tasked to mediate and co-ordinate such agreements. On TOA, the OpCdr and /or FCdr will be responsible for the H&M Support of assigned forces as delegated.

79. General logistic principles laid down in this document generally also apply to the H&M Support function. However, the planning and conducting of H&M Support is governed by specific medical principles and guidelines, which are laid down in the H&M Support Concept for EU-led military CMOs (Reference M). These are inter alia related to the code of medical ethics and national and international laws and standards including the law of armed conflict, when applicable.

H. LOGISTIC RELATED AREAS

1. Reception, Staging, Onward Movement & Integration

80. RSOM&I is part of the process that enables deploying forces, consisting of personnel and materiel arriving in the JOA, to become capable of meeting the FCdr's operational requirements. The sequence of the elements of RSOM&I can vary depending on the operational environment.

81. Unity of effort and synchronisation are the most important principles. Unity of effort is achieved through a defined chain of command of RSOM&I activities and synchronisation through the integration of the RSOM&I plan into the operational planning process.

82. RSOM&I is directly related with M&T, mainly at the strategic deployment stage. There must be close co-ordination between the designated EU HQ(s) and TCNs to ensure that strategic deployment meets the requirements established in the EU military Cdrs' OPLAN.

83. The capability to manage RSOM&I activities with the flexibility to adjust the planned schedule as a result of incidents during the total process is one of the keys to success. Software tools which provide robust en-route visibility and reporting capability of Ports of Embarkation (POE) and POD are vital to plan, co-ordinate, execute and monitor the state of EU-led Forces along the RSOM&I continuum.

84. The principles and policies are further elaborated in the EU Concept for Reception, Staging, Onward Movement & Integration for EU-led Operations (Ref N).

2. Financing and Budgeting

85. The TEU, Title V, Article 28 sets the principles of expenditure for military operations. Under Title V, article 28 (2) of the TEU, "administrative expenditure which the provisions relating to the areas referred to in this title entail for the Institutions shall be charged to the EU budget". Under article 28 (3) of the TEU, operating expenditure arising from operations having military or defence implications shall be charged to the MS (Ref O). MS have established a mechanism, called ATHENA (Ref. P), with the necessary legal capacity to administer the financing of the common costs of EU operations having military or defence implications.

I. MODES of Logistic Support

1. Introduction

86. The modes of logistic support available to EU-led military operations range from a fully multinational integrated logistic support to purely national support. The chosen mode or a combination of them will, among others, depend on the type, scale, and size of an operation, and on the characteristics and factors affecting logistic support. The following list of modes of logistic support does not necessarily reflect a priority order.

2. National Logistic Support

87. Notwithstanding any multinational arrangements, TCNs are ultimately responsible for ensuring that forces assigned to EU-led military operations are fully supported and fit for task.

88. TCNs could deploy NSEs to provide logistic support to their national forces deployed in EU-led military operations. A NSE is a national logistic organisation that supports national forces which are part of an EU-led Force. These logistic units remain under the command of their national authorities. NSEs should co-ordinate and co-operate with the FCdr and the HN(s). Therefore, the FCdr should have LOGCON over the NSEs.

3. Multinational Logistic Support

89. TCNs contributing to the force will consider whether multinational arrangements will provide benefit or whether it will conflict with their national interest. The benefits of multinational logistic support could be the optimisation of the logistic footprint, reduction of logistic deployment package and reduction of costs.

a. Framework Nation

90. FN is defined (Ref. Q) as "A member State or a group of Member States that has volunteered to, and that the Council has agreed, should have specific responsibilities in an operation over which EU exercises political control. A FN provides the OHQ/FHQ and the core of the military chain of command, together with the Staff support, the CIS and the logistic framework, and contributes with a significant amount of assets and capabilities to the operation".

b. Logistic Lead Nation and Logistic Role Specialised Nation

91. A TCN can be a LLN if it assumes the overall responsibility for organising and co-ordinating an agreed broad spectrum of logistic support for all or part of the multinational force, including headquarters, within a defined geographical area for a defined period of time. The LLN could concurrently provide capabilities as Logistic Role Specialised Nation (LRSN).

92. One TCN assumes the responsibility of LRSN when it assumes the responsibility for procuring and providing a specific logistic capability and/or service for all or part of the multinational force within a defined geographical area for a defined period of time.
93. During the build up of an EU-led military operation it is necessary to identify, if possible, one LLN and one or more LRSN. TCNs participating in an operation need to recognise the vital importance of ensuring efficient logistic support. The OpCdr is responsible for the FG Conference, which should address details of multinational logistics.
94. During the process to identify a LLN or LRSN, negotiations through the logistic support planning process are conducted with each TCN requiring support. The aim of negotiations is to determine the exact range of responsibilities of LLN/LRSN and to ensure that the SOR provides sufficient freedom of action to carry out the Cdr's Plan.
95. There are elements that require specific considerations such as legal framework, duration of the task, C2, quality and level of support based on standards pre-defined or defined during the FG process and the Logistic Conferences.
96. The LLN should, among others:
- Take into account all applicable regulations affecting the logistic support of other TCNs forces for which they have the lead;
 - Assume the lead in co-ordinating HN tasks and responsibilities, to the extent permitted by relevant arrangements with the HN, or if no recognised HN authority exists, by the FCdr, in consultation with participating TCNs;
 - Assume the lead in performing specific tasks as identified by the OHQ Logistic Co-ordination Centre (OHQ LogCoC);
 - Assume responsibility to establish the logistic C2 structure.
97. A LRSN should, among others:
- Take into account all applicable regulations affecting the logistic support of other TCNs forces for which they are undertaking the specialist role;
 - Take into account the mechanism to be compensated and/or reimbursed for services and/or capabilities provided, subject to agreements between the parties involved.

c. Multinational Logistic Arrangements

98. When it is not possible to identify one LLN or one or more LRSNs, or when those are not able to fully support operational requirements, the establishment of multinational arrangements may be necessary.

99. TCNs should activate or consider entering into bilateral or multilateral arrangements aimed at sharing logistic resources in order to resolve logistic shortfalls or when it is operationally effective and efficient.

100. The establishment of multinational arrangements will commence from the earliest stages of operational logistic planning. Bilateral or multilateral support agreements made between a number of participating TCNs could also be activated at the onset of an operation.

101. At the request of TCNs, such logistic support may be co-ordinated by appropriate logistic structures activated for the EU-led military operations, for example a OHQ LogCoC at the military strategic level or a Multinational Joint Logistic Centre (MJLC) or by a FHQ Logistic Co-ordination Centre (FHQ LogCoC) at the theatre level.

d. Multinational Integrated Logistic Unit and Multinational Logistic Unit

102. Multinational Integrated Logistic Unit (MILU) and Multinational Logistic Unit (MLU) are military units formed by two or more TCNs to provide logistic support to a multinational force under a single command.

103. The main difference between a MILU and a MLU is that a MLU normally remains under national command and control as opposed to a MILU which is OPCON to the FCdr.

104. The use of MILUs and MLUs could be an appropriate solution to achieve economies of scale, improve efficiency and to resolve logistic shortfalls. The MILU and MLU concept is particularly important as a force generation tool, particularly in low intensity operations or operations with a prolonged duration where logistic force contributions would be difficult to generate without co-operation. These multinational logistic units are designed to provide specific logistic support where national forces cannot be provided, or could be better utilised to support the OpCdr/FCdr overall logistic support plan. They are an important mechanism or enabler by which some TCNs may contribute more effectively to the overall operational effort.

105. The MILU and MLU Cdrs should have clear authority over sub-units, normally OPCON/LOGCON. This support option might be particularly attractive when a single TCN is capable of providing the nucleus of the unit and/or the command structure around which the whole unit can be formed by augmentation and/or the addition of complementary units from other nations. One nation should be in charge of setting up the unit by providing the C2 structure and Communication and Information Systems (CIS) framework. Specific C2 and operational arrangements will be negotiated between participating TCNs.

106. A MILU and MLU have the general tasks defined hereunder:

- Acquire the agreed supplies and/or services as directed by the FCdr or appropriate authority;
- Provide agreed supplies and services to an EU-led Force as directed by the FCdr or appropriate authority.

4. Host Nation Support

107. HNS is civil and military assistance, rendered by a HN to another State and/or organisation which has forces located on, operating on/from, or in transit through the HN's territory⁵. The basis of such assistance arises from bi- and/or multilateral agreements.

108. HNS seeks to provide deployed forces with support in the form of material, transportation assets, facilities and services, including area security, administrative support in accordance with concluded HNS arrangements between the EU and/or Sending Nations and a HN(s). The term HNS arrangements cover all bi- and multilateral agreed HNS documents.

109. As such, HNS may facilitate the movement of forces in the JOA by providing essential RSOM&I support. The level of HNS depends on the capability and willingness of the HN(s) and the availability of local resources in order to support an EU-led Force. Therefore, HN(s) may reduce the required logistic footprint to deploy, sustain and re-deploy the EU-led Force⁶.

⁵ Territory: The extent of land, airspace and interior of the earth above and below this extent of land, and the territorial waters adjacent to a coastal state.

⁶ This includes EU military organisations, groups, bodies or other entities specifically set up for the operation.

110. HNS planning is an integral part of military logistic support planning, and it may have an impact on the FG process. When appropriate, the HN(s) provides national logistic experts for the relevant phases of logistic planning and execution. HNS planning should be as specific as possible and related procedures should be standardised to enable the HN(s) to evaluate and respond efficiently and flexibly to requirements due to the operational needs. However, the variety of tasks in the entire range of possible EU-led military operations will require a generic approach to be taken towards HNS planning.

111. If possible, full advantage should be taken of logistic resources available under HNS agreements/arrangements. If such agreements/arrangements do not already exist, the OpCdr is responsible for establishing requirements, in consultation with TCNs. These responsibilities may include initiating and participating in bilateral and multilateral negotiations and, where appropriate, for concluding HNS arrangements on his own (possibly common funded) or, subject to their prior concurrence, on behalf of TCNs. All or part of this activity can be delegated to the FCdr. HNS does not include local contracting.

112. In-theatre local resources may be scarce and HNS arrangements limited or even non-existent, therefore, military logistic planning must take particular account of the specific political and economical (e.g. risk of cannibalising the local market, increasing competition) situation as well as the geographic and infrastructure conditions in theatre.

113. HNS principles and policies are further elaborated in the HNS Concept for EU-led military CMOs (Ref. R).

5. Contracting and Third Party Logistic Support

114. Contracting can either be a response to unforeseen logistic requirements that arise during the course of an operation or the outsourcing of EU requirements to contractors for capabilities not met through the FG process. The last-minute nature of ad-hoc contracting, and the time required to secure funding approval, can result in increased costs and delayed delivery of the required capabilities, therefore the advantages and limitations of Contracting/TPLS need to be considered throughout the logistic planning process.

115. TPLS is the use of pre-planned contracts to provide logistic supplies, logistic services and even logistic functions through civilian companies.

116. As an increasing number of civilian companies are able to provide logistic support for EU-led military operations in an austere environment, both contracting and TPLS are becoming increasingly important in support of EU-led military operations. Early or pre-identifying civilian sources of supplies and services and integrating them into the overall operational requirements can lead to a reduced logistic footprint.

117. Contracting may be carried out by TCNs and/or EU military Cdrs, depending on the cost, category or specific arrangements. Contracting/TPLS can complement or replace HNS. Care must be taken to avoid compromise to the operation by uncoordinated and competing contracting action.

118. MS have to clearly define what could or could not be outsourced and what standards to use when considering outsourcing options. In this respect, TPLS may be useful to ensure timely availability of scarce support. Co-ordination and co-operation, in this subject, among TCNs are essential to gain economies of scale and avoid escalation of prices that could have a subsequent implication in theatre.

119. In-theatre contracting/TPLS must be integrated in the C2 structure and appropriately trained and accredited for the requirements of EU-led military operations. Contracting/TPLS can also introduce limitations as a result of employing civilians in the JOA. There may be issues of force protection and security that could reduce flexibility. This must be taken into account during the logistic planning process.

120. TCNs should accept standards as binding standards for EU-led military operations (subject to agreement on regulated EU standards for the different services on EU-led military operations).

6. Recourse to NATO Common Assets and Capabilities

121. The area related to the planning and conduct of EU-led military operations with recourse to NATO common assets and capabilities is known as "Berlin Plus" arrangements (Ref. S). This encompasses assured EU access to NATO planning capabilities, use of NATO's European command options for EU-led military operations (including the European role of DSACEUR), and the EU use of pre-identified NATO common assets and capabilities (Ref T).

122. In case of recourse to NATO common assets and capabilities for EU-led military operations, the NATO Maintenance and Supply Agency (NAMSA) might be considered as a contracting agency, if appropriate.

J. LOGISTIC INFORMATION AND MANAGEMENT

123. TCNs have a collective responsibility for logistic support of EU-led military operations, ensuring that the appropriate levels of authority have access to information on the status of all assets, specifically for mission critical items, during the whole operation.

124. The exchange of relevant information between EU actors, TCNs, Third States and others concerning logistic assets and capabilities is essential for the efficient planning, management and co-ordination of logistic support and related activities to EU-led Forces. The exchange of information between TCNs and EU military Cdrs, concerning logistic resources and capabilities related to their responsibility and mission, is essential to ensure the proper execution of the logistic support to EU-led Forces

125. To achieve this exchange of information, it is necessary to identify what logistic information the EU-led military operation needs and to develop specific software tools, which should be interoperable with logistic systems of MS/non EU TCNs and others systems used by EU actors. This will allow the EU military Cdrs of an EU-led military operation to have all the information they need quickly and accurately.

126. The characteristics of logistic information and management systems to conduct EU-led military operations should be related to new management concepts and information technology opportunities, not only referring to software, but also to organisational procedures. A logistic information and management system for an EU-led military operation should specifically focus on flexibility, integration, and the interfaces with other EU actors and MS/non-EU TCNs systems.

K. LOGISTIC PLANNING

127. Military logistic planning at the political and strategic level will be developed within the framework of advance and crisis response planning, including the development of the Crisis Management Concept (CMC) and Military Strategic Options (MSOs) (Ref. U).

128. Military logistic planning must be versatile, complementary to the mission aim and fully integrated within all phases of the Operational Planning Process (OPP).

129. Military logistic planning and its subsequent execution in support of EU-led military operations should be carried out and co-ordinated on a combined, joint and military/civil basis, as appropriate.

130. Military logistic staff members need to be involved from the very beginning of the planning process, including FG, and must be included in area reconnaissance/site survey activities and Fact Finding Missions (FFM).

131. Military logistic planning is an iterative process that starts from a common baseline and develops through successive refinements. It integrates EU actors and TCNs abilities to form, deploy, receive, onward move, sustain and re-deploy military forces by incorporating national, multinational and in-theatre resources, as authorised. It involves both military and civil authorities and encompasses all the logistic functions and logistic related activities. Overall, logistic planning provides a significant input to the military operational planning process and, due to the complexity of EU-led military operations, it has to be initiated at the earliest stage of any arising crisis, involving relevant EU actors.

132. The possible participation of non-EU TCNs in EU-led military operations highlights the need for a high level of co-operation and co-ordination to ensure that those are integrated in the planning process as quickly and as fully as prevailing circumstances permit.

133. In the event that the EU takes over an ongoing operation, it is essential that existing logistic plans and arrangements are reviewed thoroughly and amended as necessary at all appropriate levels of the chain of command. A logistic directive should be issued by the OHQ as a part of the OPLAN or as a stand-alone document.

134. Military logistic planning at the military strategic level will be developed within military operational planning (Concept of Operations (CONOPS) and OPLAN), for which the OpCdr is responsible. This level is responsible to coordinate the identification, generation, activation and deployment of the forces and resources necessary for the operation. The logistic support could be co-ordinated by appropriate logistic structures activated for EU-led military operations, at this level by an OHQ LogCoC.

135. Logistic planning at the military operational level will be developed within military operational planning, Operation Order (OPORD), for which the FCdr is responsible. This level is responsible for logistic support in the JOA that could be co-ordinated by appropriate logistic structures activated for EU-led military operations; at this level by a MJLC or a FHQ LogCoC.

136. Logistic Planning Conferences are an essential tool by which military logistic planning is co-ordinated and transparency is achieved. The type of planning will dictate the timing and frequency of conferences. Specialist conferences, H&M Support, M&T, HNS, RSOM&I, etc, may also be necessary.

137. Logistic FG process will be dealt with within the overall FG process (non-EU TCNs should be brought into the FG Process at the earliest possible stage and, where appropriate, their logistic capabilities should be identified within the planning process).

L. COMMAND AND CONTROL STRUCTURE. TASKS AND RESPONSIBILITIES

1 General

138. Since there is no permanent EU C2 structure, the C2 arrangements will be tailored to the specific needs of an EU-led military operation. Levels of command are defined in the EU Concept for Military Command and Control (Ref. V).

2. Political and Strategic Level

a. Troop Contributing Nations

139. The responsibilities of TCNs are, among other:

- a. Take the necessary measures for planning and conducting the logistic support of their forces, and national components of multinational forces, to meet the requirements of the OpCdr, co-ordinated through the OHQ LogCoC;
- b. Be responsible for providing logistic resources for the support of their forces, including through bilateral or multilateral arrangements;
- c. Identify national logistic resources available for co-operative use to meet identified shortfalls in military operational logistics plans;
- d. Operate and control national military and civil logistic resources for the operation;
- e. Provide national logistic experts for the relevant phases of logistic planning and execution to augment the EU logistic co-ordination bodies;
- f. Agree to co-operative arrangements by identifying TCNs that could take the lead in performing specific tasks identified by the EU Logistic Co-ordination Group (EU LogCoG) or OHQ LogCoC.

140. The contribution of non-EU TCNs will be governed by a participation agreement, which can be generic or specific to one operation. The EU has developed a draft model Framework Participation Agreement (Ref. W) and a draft (operation specific) Model participation agreement (Ref. X). As a result some framework participation agreements with some Third States have been concluded.

b. Other Contributions

141. Any states not committing forces to the operation may offer support, assets and/or funding for the operation. Where appropriate, they may provide national logistic experts for the relevant phases of logistic planning and execution.

c. Council and Council Bodies

142. The responsibilities of the Council and Council bodies, the Political and Security Committee (PSC) and EU Military Committee (EUMC), are set out in the Nice European Council Conclusions (Ref. Y), the TEU, in relevant Council Decisions and in the Suggestion for procedures for coherent, comprehensive EU Crisis Management (Ref. Z).

d. European Union Military Staff

143. In the event of an operation, logistic capabilities, both quantitative and qualitative, should be assessed throughout. In the event of an EU-led military operation, and pending the nomination of the OpCdr and the identification of the OHQ, the EUMS reinforced as necessary by logistic experts from MS could provide logistic inputs during the decision-making process.

144. The EUMS has the following tasks:

- a. Monitor and take initiatives for the development of logistic doctrine/concepts and procedures in the field of multinational logistic support for EU-led military operations in consultation with MS;
- b. Develop logistic elements of advance military strategic planning;
- c. Develops and update, following EUMC guidance, the logistic elements of generic and/or contingency plans, MSOs, Initiating Military Directive (IMD) and evaluate, from the logistic point of view, the CONOPS/OPLAN;
- d. Consult with MS, Third States and IOs, and convene logistic expert meetings;
- e. Take initiative to form and chair the EU LogCoG if/when required to support logistic planning and conduct of an EU-led military operation;

- f. Provide necessary co-ordinated inputs, assessments and draft military advice in all logistic affairs throughout direction of an EU-led military operation.

145. EU Logistic Coordination Group

- a. To cover the increased need for experts during operations, EUMS may be reinforced as necessary, and an EU LogCoG may be activated. Logistic experts from MS, non-EU TCNs, Third States, NATO or other relevant organisations may be invited to participate in the proceedings.
- b. The EU LogCoG, if activated, has the following tasks:
 - Analyse the MS and non-EU TCN replies to assess the likely logistic requirements against MSOs;
 - Assist in drafting the logistic inputs to the CONOPS/OPLAN;
 - Initiate and co-ordinate preparation for logistic support options, until this function is taken over by the OHQ LogCoC.

146. EU Movement Planning Cell

- The EUMS' EU Movement Planning Cell (EUMPC) is responsible for undertaking advance military strategic planning and crisis response military strategic planning with regard to strategic M&T issues. The EUMPC might also undertake some of the tasks and responsibilities, normally undertaken by the EUMCC, for EU-led military operations when an OHQ has not yet been activated.

3. **Military Strategic Level**

Operation Commander

147. The OpCdr has the following logistic responsibilities:

- a. Draft CONOPS/OPLAN including the logistic annexes;
- b. Plan and co-ordinate the strategic deployment including RSOM&I, sustainment and redeployment of EU-led forces. On TOA the OpCdr is responsible for the co-ordination of the overall logistic support. Responsibilities and procedures will need to be refined throughout the OPP;
- c. Develop all the operational requirements for logistic planning and execution necessary for comprehensive logistic support including a sustainability statement to be issued as part of the OHQ Logistic Directive;

- d. Establish requirements, initiate and participate in bilateral and multilateral negotiations, and, where appropriate, conclude MOU, TAs and other HN(s) arrangements on behalf of TCNs within the limits of the authorisation given to them in advance;
- e. Conduct redistribution under agreed provisions (if required);
- f. Provide a staff organisation and support for the OHQ LogCoC;
- g. Conduct co-ordinating authority in the field of logistics through the OHQ LogCoC.

148. OHQ Logistic Co-ordination Centre.

- a. The OHQ LogCoC may be established at the OHQ. It would be composed of OHQ logistic staff, logistic experts from TCNs and a temporary EUMS liaison element. It may also include NATO Logistic experts, if the operation is conducted using NATO common assets and capabilities under Berlin Plus arrangements.
- b. The OHQ LogCoC has the following tasks:
 - Serve as a primary logistic Point of Contact (POC) for TCNs;
 - Assist the OpCdr in drafting the logistic input to the CONOPS/OPLAN;
 - Co-ordinate, prioritise and de-conflict national and multinational logistic support issues, in accordance with strategic requirements;
 - Co-ordinate the allocation of the support, assets and/or funding for the operation offered by other than MS, non-EU TCNs and Third States.

4. **Military Operational Level**

a. **Force Commander**

149. The FCdr has the following logistic responsibilities:

- a. Develop logistic inputs and plans as applicable to OPLAN/OPORD;
- b. Assist in development of the Sustainability Statement developed by the OpCdr;
- c. If tasked, establish requirements, initiate and participate in bilateral and multilateral negotiations, and, where appropriate, conclude MOU, TAs and other HNS arrangements on behalf of TCNs within the limits of the authorisation given to them in advance;
- d. Co-ordinate the activities of the NSEs through the MJLC or FHQ LogCoC;
- e. Conduct redistribution under agreed provisions (if required);
- f. Co-ordinate all aspects of multinational logistic sustainment in the JOA;
- g. Control and establish procedures for intra-theatre movements;

- h. Control multinational integrated logistic support including MILUs;
- i. Recommend to the OpCdr any necessary changes concerning force deployment (desired order of arrival, commander's required date, etc), transportation for sustainment (re-supply) and redeployment;
- j. Implement common funding under the authority of the OpCdr;
- k. Conduct the RSOM&I process in the JOA.

At FHQ level, the logistic structure could be as follows:

150. Multinational Joint Logistic Centre.

- a. The MJLC is a multinational logistic organisation responsible for the centralised co-ordination and/or management of common logistic functions. It is to control multinational integrated support where appropriate. It acts as an executive arm for the policy and planning conducted within the CJ-4. A MJLC capability could be created by either augmenting the CJ-4 staff or integrating it in, or co-locating it with another supporting HQ. In a complex large-scale operation it could be a stand-alone organisation.
- b. A MJLC has the following responsibilities:
 - Assist the FCdr in co-ordinating logistic support within the force, including the creation and control of multinational integrated logistics and commonly funded resources;
 - Assist the FCdr in co-ordinating movement, logistic support and other military functions if tasked by higher authority, between the components, NSEs, HNs IOs and NGOs;
 - Co-ordinate the implementation of HNS agreements;
 - Co-ordinate the implementation of TPLS contracts;
 - Where appropriate, and as authorised by TCNs, co-ordinate and arrange the provision of common supplies and services;
 - Co-ordinate and administratively support national, NGO and HN(s) liason staffs within the MJLC according to specific arrangements;
 - Establish and manage local contracts.

151. FHQ Logistics Co-ordination Centre.

When a MJLC is not established, a FHQ LogCoC can be activated. It will be composed of logistic experts from TCNs (usually from their NSEs) and other organisations. The centre serves as an in-theatre forum for co-ordination and de-confliction of logistics in accordance with operational requirements.

b. National Support Element

152. A NSE is any national organisation that supports national forces which are part of EU-led Forces. NSEs remain under their own national authorities, and are normally not part of EU-led Forces. Their mission is nation-specific support to units and common support that is retained by the nation. NSEs should co-ordinate and co-operate with the FCdr and the HN(s). Co-operation and centralisation of services among NSEs can produce significant savings. The agreed SOFA regulations are applicable to NSEs.

The NSEs have the following responsibilities:

- Co-ordinate with the force logistic organisation in-theatre;
- Support RSOM&I, transportation for deployment/redeployment and sustainment of national forces;
- Report critical operational assets and activities;
- Manage costs, handing over, settlement of claims of properties and real estate occupied by national troops;
- Provide assistance, if requested and within means and capabilities, to other national contingents or the whole force according to agreed arrangements, or the co-ordination of the appropriate EU C2 structures.

5. Military Tactical Level

Logistic Support Command

153. For major EU-led military operations, the number and size of multinational and national logistic support units in the JOA could be considerable. To co-ordinate the required logistic support, a specific Logistic Support Command (LogSptCd) could be established.

154. The Logistic Support Commander (LogSptCdr) tasks and responsibilities, if established, should be defined at OHQ and FHQ levels through Standard Operating Procedures (SOP) and other specific documents.

6. Structure Outline

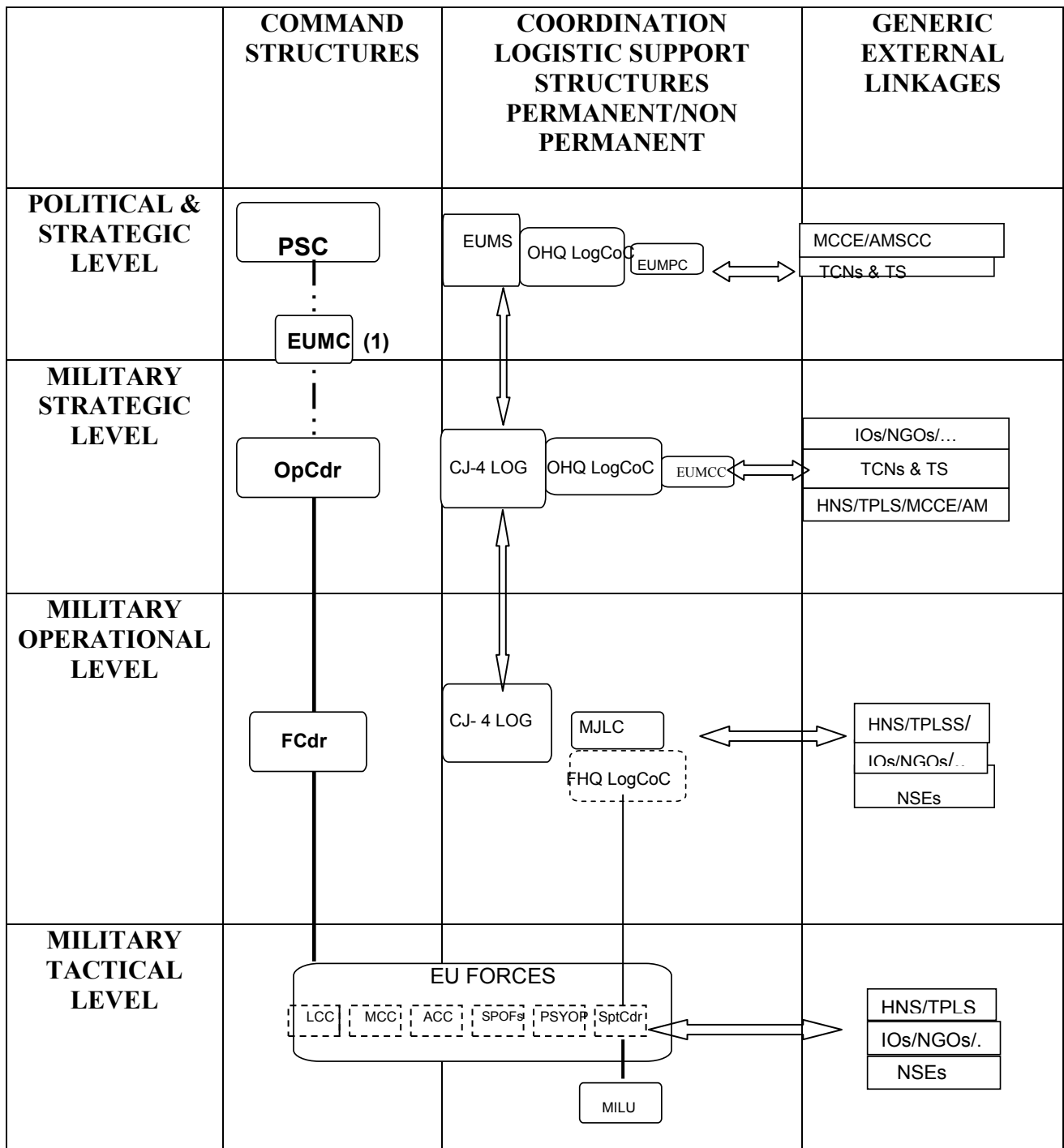

(1) CEUMC acts as a primary POC

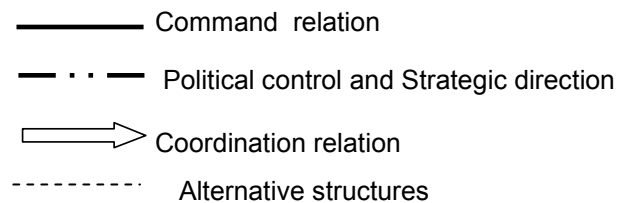

Annex A

LOGISTIC PLANNING CONFERENCES

A. LOGISTIC EXPERTS MEETINGS

During all the phases of a crisis, but particularly at the outset, the EUMS may need to convene logistic meetings with representatives from MS, non-EU TCNs, Third States, NATO, multinational and national HQs, and other relevant IOs. Such meetings may take place prior to the force activation process in order to inform, allow full exchange of views and to prepare for further logistic planning conferences. The principal conferences are described below but additional conferences may be held if necessary.

B. INITIAL LOGISTIC PLANNING CONFERENCE

Convened by the EU OpCdr with participation of the MS and invited Third States, the Initial Logistic Planning Conference (ILPC) is usually held once the CONOPS is developed. The purpose is to:

- a) Inform MS and Third States if applicable, about the mission and the CONOPS;
- b) Analyse, evaluate and explain all factors influencing the logistic planning;
- c) Refine the logistic concept for the operation;
- d) Discuss and propose the logistic C2 structure.

This conference should assist in enabling the OpCdr's logistic staff to develop the logistic elements of the CONOPS and to provide the information necessary to commence further logistic planning.

C. MAIN LOGISTIC PLANNING CONFERENCE

Convened by the EU OpCdr with participation of MS and invited Third States as well as FHQ if applicable, the Main Logistic Planning Conference (MLPC) is held when the first draft of the force requirements and the first draft of the OPLAN are available. The purpose is to:

- a) Explain and discuss the OPLAN;

- b) Identify the logistic requirements;
- c) Identify common logistic functions and procedures as well as HNS funding and legal issues;
- d) Identify elements of the logistic plan to be undertaken on a multinational basis including the establishment of MILUs/MLUs (if agreed upon);
- e) Commence the logistic force balancing process;
- f) Resolve any issues outstanding from the ILPC;
- g) Resolve any outstanding issues regarding the assignment of LLN and LRSN.

The result of this conference will be to enable the OHQ logistic staff to develop the SOR and to finalise the logistic Annexes of the OPLAN. It should allow them to initiate HNS negotiations (if authorised) and to address funding and legal issues. In addition, it will provide TCNs if applicable, with the information to develop further and detail national logistic plans.

D. FINAL LOGISTIC PLANNING CONFERENCE

Convened by the EU OpCdr with participation of the MS and invited Third States as well as FHQ staff if applicable, the Final Logistic Planning Conference (FLPC) is held when the TCNs have formally committed forces. The purpose is to:

- a) Finalise and confirm logistic planning;
- b) Optimise the overall logistic support to the operation;
- c) Confirm the logistic C2 architecture;
- d) Resolve any remaining deficiencies or outstanding logistic issues.

The result of this conference should be a balanced and harmonised match of requirements to resources and the OPLAN and national logistic plans.

E. LOGISTIC PLANNING REVIEW CONFERENCE

Convened by the EU OpCdr with participation of the TCNs as well as FHQ staff if applicable, the Logistic Planning Review Conference (LPRC) is held when the TCNs have formally committed forces. This conference is optional and will only be held if changes in the military situation require fundamental adjustment of the logistic plan, or if the identified logistic shortfalls could jeopardise the mission. The purpose is to:

- a) Resolve deficiencies or adopt new measures in logistic support.;
- b) Review and adjust the CONOPS and/or OPLAN.

F. TERMINATION OF OPERATION

Planning for the conclusion and long-term consequences of the operation must be considered from the outset, together with the means to achieve it. The logistic planning will have to centre upon two main activities, notably redeployment and post-operation activities, and will require, at least, the same number of conferences as for the initial OPP.
